

case study

providing E1 TDM/ATM interworking and traffic consolidation in the Access Network

A major telecoms equipment manufacturer re-engaged Asidua following successful development and deployment of an SNMP Agent on the manufacturer's ATM Switch Fabric card.

The remit was to design and develop the software for a new card that would offer E1 TDM/ATM interworking and traffic consolidation. The card would allow telecom network operators to make more efficient use of their core network bandwidth using a Circuit Emulation Service (CES) to transport E1 TDM traffic.

technology mix

Platform

- vxWorks running on PowerPC

Communication Devices

- PMC-Sierra TEMUX-84 (T1/E1 Framer)
- PMC-Sierra IMA-84 (Inverse Multiplexer for ATM)
- PMC-Sierra AAL1gator-32 (CES AAL1 SAR)

ATM Based Technologies

- E1/UNI
- IMA
- CES (AAL1)

Telecommunications

- ATM
- SDH
- E1 structured/unstructured
- Synchronous/Adaptive/SRTS timing

Interface Bus Architecture

- Telecom Bus
- Scalable Bandwidth Interconnect (SBI)
- Any-PHY Bus

□ key objectives & specification

Asidua was tasked with development of the card software to support the following key features:

- E1/UNI
- IMA
- AAL1 CES
- Synchronous, Adaptive and SRTS timing support
- Alarm processing
- Performance Monitoring
- Integration with Management Card

A major challenge in this project was that prototype hardware would not be available until late in the software development process.

□ successful outcomes

Asidua quickly developed excellent working relationships across the manufacturer's departments, from Systems Engineering and Development to Production.

Despite the lack of hardware, Asidua proceeded with the design and development of the software. They were quick to realise that a similar card had two of the three devices to be used, and moved to make use of this to allow early testing of the software. The software associated with the remaining device was developed on a host system. It was then ported to the existing card where it was used with a suite of stub code. This approach minimised the time needed to integrate the software when the actual hardware arrived.

Extensive use of test automation using the Expect scripting language allowed Asidua to produce a suite of regression tests. This ensured Alarm processing and Performance Monitoring continued to operate correctly, whilst freeing up engineers to concentrate on other development tasks.

Following deployment with the end-customer, Asidua were re-engaged to enhance the software for:

- Partial Cell Fill to minimise delay
- ATM F5 OAM support for Loopback, VC-AIS, VC-RDI

□



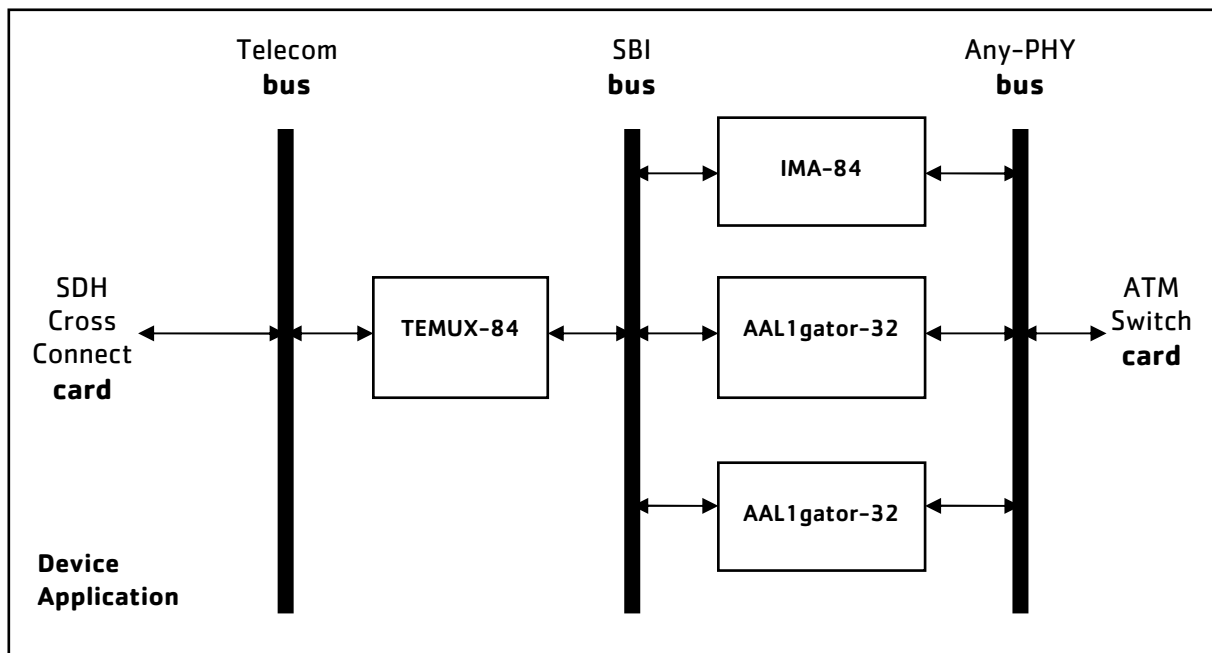

extra dimension

What is the “extra dimension”? It’s the unusual passion for software technology, the world-class engineering talent and teamwork, the industry experience, and the quiet pride that Asidua’s Device Services Division team takes in its work articulates the essence of the “extra dimension” of quality service that it consistently delivers.

Whilst providing E1 TDM/ATM interworking and traffic consolidation, Asidua provided the Extra Dimension in the following ways:

- **initiative**

Asidua were not concerned about the lack of target hardware. Instead, they made use of what hardware was currently available to them to allow software design and development to progress

- **host based development**

Even when faced without devices to test with, Asidua proceeded to develop and test the driver software on a host system and associated suite of stub software

- **extensive automated testing**

Recognising that time is money, Asidua made extensive use of test automation, freeing up engineer time to be spent on other development tasks

In addition to this, the quality procedures and management capabilities of the project managers ensured that the specialist knowledge of the Asidua Device Services Division team was harnessed effectively

The overall result of Asidua’s involvement was that the project was delivered to the customer on time, to specification and to an excellent standard of quality.

□